

ONKYO® SERVICE MANUAL

Integrated Stereo Amplifier MODEL A-8200

U D	120V AC, 60Hz
U G	220V AC, 50Hz
U Q (A,B)	240V AC, 50Hz
U W	120V/220V AC, 50Hz/60Hz

SAFETY-RELATED COMPONENT WARNING!!

COMPONENTS IDENTIFIED BY MARK Δ ON THE SCHEMATIC DIAGRAM AND IN THE PARTS LIST ARE CRITICAL FOR RISK OF FIRE AND ELECTRIC SHOCK. REPLACE THESE COMPONENTS WITH ONKYO PARTS WHOSE PARTS NUMBERS APPEAR AS SHOWN IN THIS MANUAL.

MAKE LEAKAGE-CURRENT OR RESISTANCE MEASUREMENTS TO DETERMINE THAT EXPOSED PARTS ARE ACCEPTABLY INSULATED FROM THE SUPPLY CIRCUIT BEFORE RETURNING THE APPLIANCE TO THE CUSTOMER.

TABLE OF CONTENTS

Specifications	2
Precautions	2
Adjustment procedures.....	3
Chassis exploded view	4
Printed circuit board parts list	6
IC block diagram	9
Parts list of packing	12
System connections	12
Front panel facilities	13
Block diagram	14
Schematic diagram	15
Printed circuit board view.....	17



SPECIFICATIONS

Power Output:	60 watts per channel, min RMS, at 8 ohms, both channels driven from 20 Hz to 20 kHz, with no more than 0.06% THD. 2 x 100 watts at 4 ohms, 1 kHz(DIN) 2 x 70 watts at 8 ohms, 1 kHz(DIN)
Total Harmonic Distortion	0.06% at rated power
IM Distortion	0.06% at rated power
Damping Factor:	40 at 8 ohms
Frequency and Response:	15-30,000 Hz ± 1 dB
Input Sensitivity/Impedance:	Phono (MM): 2.5 mV/50 kohms Phono (MC): 350 μ V/220 ohms Tuner/CD/AUX, Video: 150 mV/50 kohms Source Direct: 150 mV/50 kohms Tape/Play: 150 mV/50 kohms
Output Sensitivity/Impedance:	Tape/Rec: 150 mV/3 kohms (phono)
Phono Overload:	150 mV RMS at 1 kHz, 0.06% THD (MM) (REC)
Bass Control:	± 10 dB at 100 Hz
Treble Control:	± 10 dB at 10,000 Hz
Selective Tone Control:	± 15 dB at 50 Hz/ ± 6 dB at 10 kHz
Signal to Noise Ratio (IHF-A):	Phono (MM): 80 dB (5 mV input) Phono (MC): 70 dB (0.5 mV input) Source Direct (CD): 102 dB

General

Power Supply:	USA & Canadian model: AC 120V, 60Hz European models (except U.K.): AC 220V, 50Hz U.K. & Australian models: AC 240V, 50Hz Worldwide models: AC 120 and 220V switchable, 50/60Hz
Dimensions (W) x (H) x (D):	435 x 143 x 287 mm 17-1/8" x 5-5/8" x 11-5/16"
Weight:	7.2 kg, 15.9 lbs.

Remote Control Transmitter RC-143S/142S

Transmitter:	Infrared
Signal range:	Approx. 5 meters, 16ft
Power supply:	Two "AA" batteries (1.5 V x 2)
Dimensions (W x H x D):	64 x 18 x 176 mm 2-1/2" x 11/16" x 6-15/16"
Weight:	130 grams. 4.6 oz. (including batteries)

Specifications and features are subject to change without notice.

PRECAUTIONS

1. Replacing the fuses

For continued protection against risk fire, replace only with same type and same rating fuse.

CIRCUIT NO.	PART NO.	DESCRIPTION
F901	252050	5A ST-6, Primary fuse (120V,120V/220V model)
F902,F903	252075 or 252075CC	2.5A-SE-EAK or 2.5A-SE-EAK, Primary fuse (220V,240V,120V/220V model)

2. Insulation resistance measurement (Only U.S.A. model)

Connect the insulating-resistance tester between the plug of power supply cable and the terminal GND on the back panel. Specifications; More than 10 M Ω at 500V.

3. Voltage selector (rear panel)

Worldwide models are equipped with a voltage selector to conform with local power supplies. Be sure to set this switch to match the voltage of the power supply in your area before turning the power switch on. Voltage is changed by sliding the groove in the switch with a screwdriver to the right or left.

Confirm that the switch has been moved all the way to the right or left before turning the power switch on. Models without a voltage selector can only be used in areas where the power supply is the same as that of the unit.

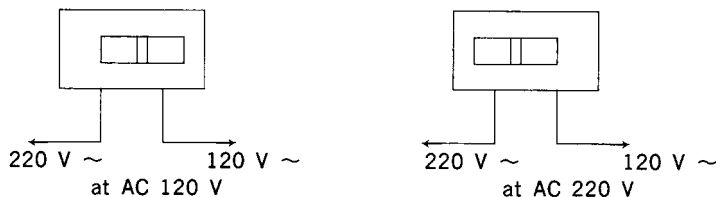

ADJUSTMENT PROCEDURES

Adjustments and Checking the Protection Circuitry

1. Preparations

- 1) Place the unit on the workbench. (There should be about 15 mm of space between the base plate of the unit and the work surface.)
- 2) Set up the unit as follows.
 - (1) No load
 - (2) No signal
 - (3) Volume turned all the way down
 - (4) Speaker switch OFF
 - (5) Power switch OFF

Note) Check the following points before making adjustments

- (1) The power switch should be OFF.
- (2) The interior of the unit should not be warm.

2. Idling current adjustment

- 1) Turn the power switch ON and allow the unit to warm up for about 10 minutes.
 - (1) Adjust R529 (R530) so that the voltage at test point VCT-ID on the NAAF-3547 circuit board is $9.5\text{mV} \pm 3.5\text{mV}$

3. Check of operation of protection circuitry

- 1) Check of operation of protection relay.
 - (1) Confirm that the relay turns ON approximately 5 seconds after the power switch is turned ON.
 - (2) The relay should turn OFF approximately 0.5 seconds after the power switch is turned OFF.
 - 2) Check of DC detection
 - (1) Turn the power on with no load.
 - (2) After the speaker relay turns ON, apply DC +1.5V to the CD input terminals. Confirm that the relay turns OFF.
 - (3) Confirm that operation is the same as (2) above when an input of DC -1.5V is applied.
- Note) Under no circumstances connect a load or short the speaker terminals when performing the above test.
- 3) Signal input from the circuit illustrated below with no load.
 - (1) Confirm that the speaker relay does not turn OFF even when a 2 ohm load is connected when a peak value of 35V p-p is output.
 - (2) Next, confirm that when a 1 ohm load is connected the speaker relay switches OFF and ON a couple of times and then stays OFF.

Note) The period before that relay stays OFF should not last for more than 10 second.
Relay OFF status can be canceled by switching the power OFF.

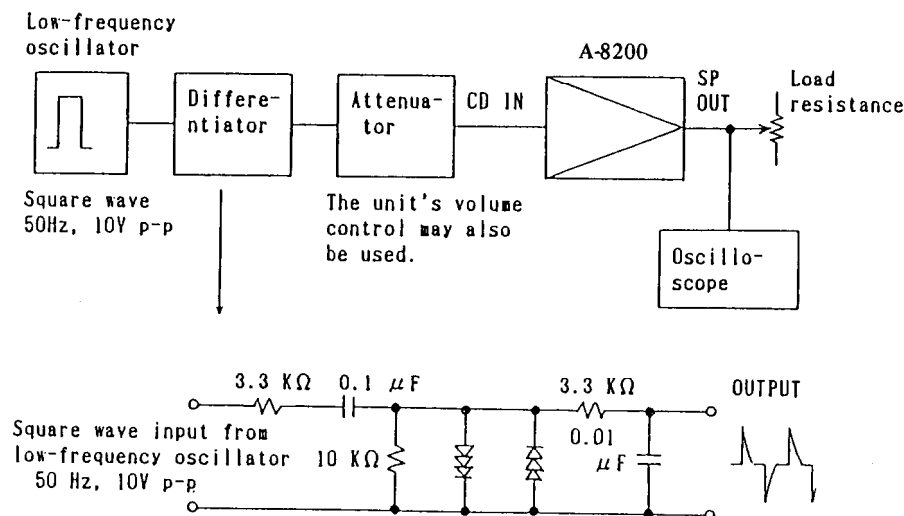

NOTE) Semi-fixed resistors enclosed in parentheses () are for the right channel.

CHASSIS-EXPLODED VIEW

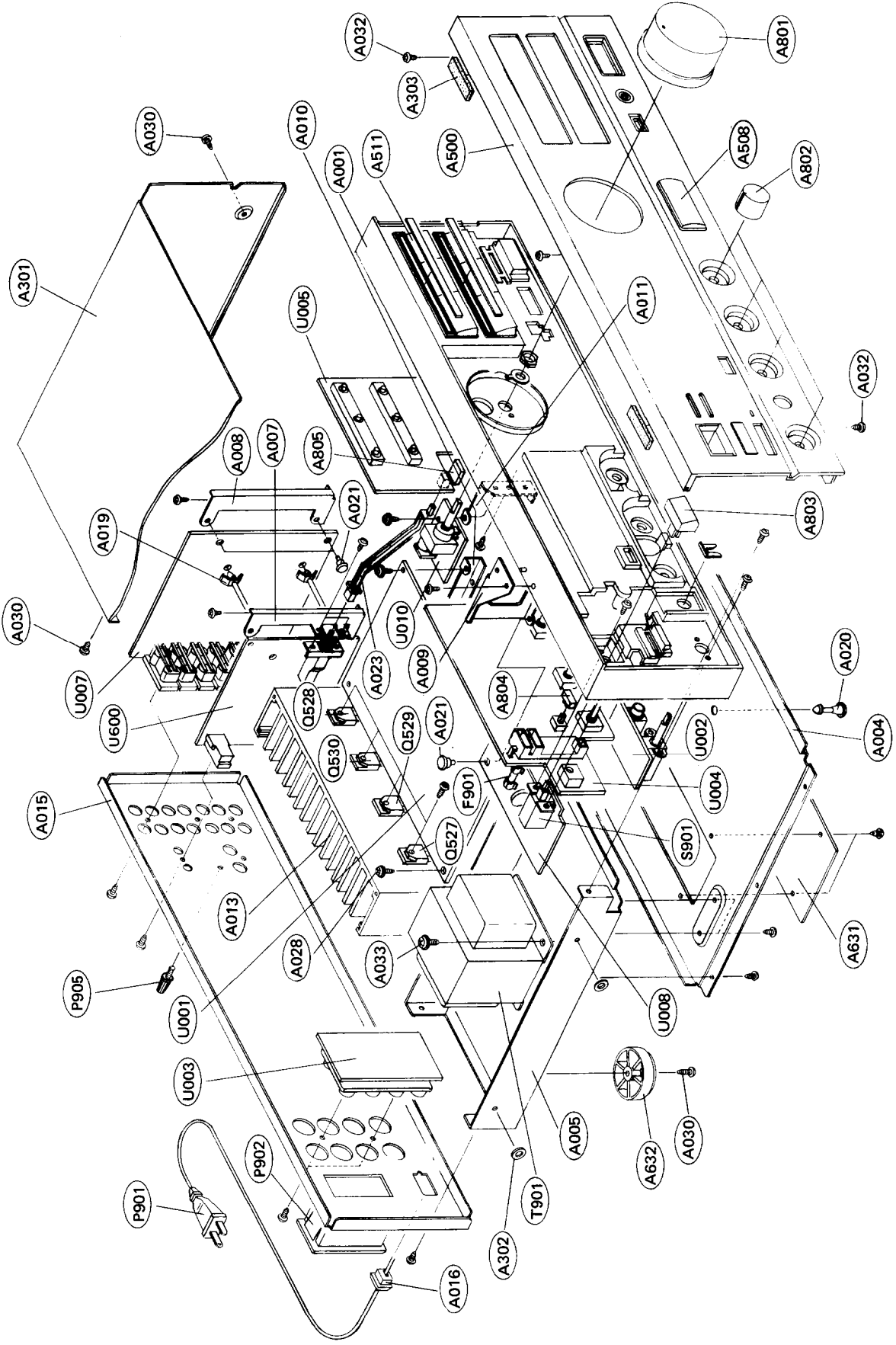

CHASSIS-EXPLODED VIEW-PARTS LIST

REF. NO.	PART NO.	DESCRIPTION	REF. NO.	PART NO.	DESCRIPTION	
A001	27110499A	FRONT ANGLE ASS'Y	△P901	253123	AS-UC-6 #18 or [D]	
(A001a)	27110476C	FRONT ANGLE		253136	AS-UC-6 #18 or [D]	
(A001b)	28323652	KNOB (SEL)		253140	AS-UC-6 #18 or [D]	
(A001c)	28323650	KNOB (SD)		253146	AS-UC-6 #18, POWER SUPPLY CABLE [D]	
(A001d)	28323644	KNOB (ST)	△P901	253149	AS-CEE, POWER SUPPLY CABLE [G][W]	
(A001e)	27190703A	HOLDER (LED)	△P901	253118	AS-SAA, POWER SUPPLY CABLE [A]	
A003	27100185	CHASSIS	△P901	72832J or	2-0.75BS16BLK or [B]	
A005	27130573B	BRACKET (PT)		728328 or	2-0.75BS16GRY or [B]	
A007	27141328	BRACKET (SW)		253104 or	C25BS2 or [B]	
A008	27141329	BRACKET (SW)		253105	C25BS2, POWER SUPPLY CABLE [B]	
A009	27141324	BRACKET (POW)		△P902	25050336	NSCT-6P163, AC SOCKET [D]
A010	27141332	BRACKET (PC)		△P902~P904	25050337	NSCT-2P164, AC SOCKET [G][W]
A011	27141325	BRACKET (VR)		P905	25060044	GROUND TERMINAL
A013	27160241A	HEATSINK		△S901	25035550	NPS-111-L512P, POWER SWITCH
A015	27121258	BACK PLATE [D]		△S902	25065123	NSS-1258P, SLIDE SWITCH [W]
A015	27121259	BACK PLATE [G]		△F901	252050	5A(ST-6), FUSE [D][W]
A015	27121261	BACK PLATE [W]		△F902,F903	252075 or	2.5A-SE-EAK or [G][W][A][B]
A015	27121262	BACK PLATE [A][B]			252075CC	2.5A-SE-EAK, FUSE [G][W][A][B]
A016	27300750	BUSHING (CABLE)			29360405	T2.5A/250A, FUSE LABEL [G][W][A][B]
A019	27190369	KGLS-22S, PC HOLDER		U001	1A169547-3	NAAF-3547-3, MAIN CIRCUIT PC BOARD ASS'Y [D]
A020	27190511	KGLS-16R, PC HOLDER		U001	1A169547-3A	NAAF-3547-3A, MAIN CIRCUIT PC BOARD ASS'Y [G][W][A][B]
A021	880009	NRP-345, REVET		U002	1A169548-3	NASW-3548-3, SPEAKER SWITCH PC BOARD ASS'Y
A023	27273118	JOINT		U003	1A169549-3	NAETC-3549-3, SPEAKER TERMINAL PC BOARD ASS'Y [D]
A028	831130088	3TTW+8B, TAPPING SCREW		U003	1A169549-3A	NAETC-3549-3A, SPEAKER TERMINAL PC BOARD ASS'Y [G][W][A][B]
A030	834430088	3TTS+8BBC, TAPPING SCREW		U004	1A169550-2	NADG-3550-2, SYSTEM CONTROL CIRCUIT PC BOARD ASS'Y [D]
A032	833430080	3TTP+8PBC, TAPPING SCREW		U004	1A169550-2A	NADG-3550-2A, SYSTEM CONTROL CIRCUIT PC BOARD ASS'Y [G][W]
A033	830440089	4TTC+8CBC, TAPPING SCREW		U004	1A169550-2B	NADG-3550-2B, SYSTEM CONTROL CIRCUIT PC BOARD ASS'Y [A][B]
A301	28184436	TOP COVER		U005	1A169551-2	NASW-3551-2, KEY SWITCH PC BOARD ASS'Y
A302	27270147	SPACER		U006	1A169552-2	NAETC-3552-2, EQUALIZER CIRCUIT PC BOARD ASS'Y [D]
A303	28140555	CUSHION		U006	1A169552-2A	NAETC-3552-2A, EQUALIZER CIRCUIT PC BOARD ASS'Y [G][W][A][B]
A500	1A169121	FRONT PANEL		U007	1A169553-2	NAAF-3553-2, SELECTOR SWITCH CIRCUIT PC BOARD ASS'Y [D]
(A502)	27267597	GUIDE (POW)		U007	1A169553-2A	NAAF-3553-2A, SELECTOR SWITCH CIRCUIT PC BOARD ASS'Y [G][W][A][B]
(A503)	27267591	GUIDE (TONE)		U008	1A169554-2	NAPS-3554-2, POWER SWITCH CIRCUIT PC BOARD ASS'Y [D]
(A504)	27267595A	GUIDE (SD)				
(A505)	28198726	PACKET (OP)				
(A506)	28198725	PACKET (SD)				
(A507)	28198727	PACKET				
A508	28135179	NAME PLATE				
A511	28191507	PLATE (SEL)				
A631	27170261	BOTTOM BOARD				
A632	27175219	BOTTOM REG				
A633	834430088	3TTS+8BBC, TAPPING SCREW				
A634	833430080	3TTP+8PBC, TAPPING SCREW				
A801	28323673	KNOB (VOL)				
A802	28323677A	KNOB (TONE)				
A803	28323241-1	KNOB (POW)				
A804	28323648	KNOB (STC)				
A805	28323646	KNOB (MC)				
Q527,Q528	2201703 or	2SC3855-O or				
	2201704 or	2SC3855-Y or				
	2201706	2SC3855-P, TRANSISTOR				
Q529,Q530	2201693 or	2SA1491-O or				
	2201694 or	2SA1491-Y or				
	2201696	2SA1491-P, TRANSISTOR				
△T901	2300440	NPT-1036D, POWER TRANSFORMER [D]				
△T901	2300441	NPT-1036G, POWER TRANSFORMER [G]				
△T901	2300442	NPT-1036DG, POWER TRANSFORMER [W]				
△T901	2300443	NPT-1036Q, POWER TRANSFORMER [A][B]				

U008	1A169554-2A	NAPS-3554-2A, POWER SWITCH CIRCUIT PC BOARD ASS'Y [G]
U008	1A169554-2B	NAPS-3554-2B, POWER SWITCH CIRCUIT PC BOARD ASS'Y [W]
U008	1A169554-2C	NAPS-3554-2C, POWER SWITCH CIRCUIT PC BOARD ASS'Y [A][B]
U010	1A169556-2	NAETC-3556-2, VOLUME CONTROL CIRCUIT PC BOARD ASS'Y

NOTE

[D]: ONLY 120V MODELS
 [G]: ONLY 220V MODELS
 [W]: ONLY 120V/220V MODELS
 [A]: ONLY AUSTRALIAN MODELS
 [B]: ONLY BRITISH MODELS

NOTE: THE COMPONENTS IDENTIFIED BY MARK Δ ARE CRITICAL FOR RISK OF FIRE AND ELECTRIC SHOCK. REPLACE ONLY WITH PARTS NUMBER SPECIFIED.

PRINTED CIRCUIT BOARD PARTS LIST

MAIN CIRCUIT PC BOARD (NAAF-3547-3,NAAF-3547-3A) PARTS LIST

CIRCUIT NO.	PART NO.	DESCRIPTION	CIRCUIT NO.	PART NO.	DESCRIPTION
	Transistors			224450512	MTZ5.1B, Zener
Q501,Q502	2212285 or 2212286	2SC2878-A or 2SC2878-B		Capacitors	
Q503~Q506	2211455 or 2210803	2SA1015-GR or 2SA733-P	C501,C502	354741009	10 μ F, 16V, Elect.
Q507,Q508	2211371 or 2211372	2SC2259-O-001 or 2SC2259-O-002	C503,C504	372121014	100 pF, 50V, Styrene
Q509,Q510	2211732 or 2211733	2SC1845-F or 2SC1845-E	C505,C506,C653	354722219	220 μ F, 6.3V, Elect.
Q511,Q512	2211255 or 2210746	2SC1815-GR or 2SC945A-P	C511,C512	354780229	2.2 μ F, 50V, Elect.
Q513,Q514	2211353 or 2211354	2SA949-O or 2SA949-Y	C513,C514	372121024	0.001 μ F, 50V, Styrene
Q515,Q516	2211633 or 2211634	2SC2229-O or 2SC2229-Y	C529,C530	371124734	0.047 μ F, 50V, Mylar
Q517,Q518	2211255 or 2210746	2SC1815-GR or 2SC945A-P	C533,C534		
Q523,Q524	2212653 or 2212654	2SC3421-O or 2SC3421-Y	C535,C536	354781019	100 μ F, 50V, Elect.
Q525,Q526	2212643 or 2212644	2SA1358-O or 2SA1358-Y	C652	354780479	4.7 μ F, 50V, Elect.
Q531,Q532	2211732 or 2211733	2SC1845-F or 2SC1845-E	C911,C912	3504206	10000 μ F, 50V, Elect.
Q651	2211455 or 2212495	2SA1015-GR or JA101-Q	C913,C914	354761019	100 μ F, 35V, Elect.
Q652	2211792 or 2211793	2SA992-F or 2SA992-E	C919,C921	354742219	220 μ F, 16V, Elect.
Q653,Q654	2211732 or 2211733	2SC1845-F or 2SC1845-E	C922	354782219	220 μ F, 50V, Elect.
Q655	2211255 or 2212485	2SC1815-GR or JC501-Q	C923	354741019	100 μ F, 16V, Elect.
Q913	2201754 or 2201755	2SD1913-R or 2SD1913-S	C925	354722219	220 μ F, 6.3V, Elect.
	Diodes		C931	354742209	22 μ F, 16V, Elect.
D501,D502	4000120	KB265, Varistor		Resistors	
D652	223163	1SS133	R527,R528	442522704	27 Ω , 1/2W, Metal oxide film
D911~D914	223897 or 22380003	P300DL or 1N5402F	R529,R530	5210064	N06HR10KBD, Semi-fixed
D917,D918	224151601 or 224651601 or 224451601	05AZ16X or HZ16EB1 or MTZ16A, Zener	R535,R536	442529104	91 Ω , 1/2W, Metal oxide film
D919	224150623 or 224650623 or 224450623	05AZ6.2Z or HZ6.2EB3 or MTZ6.2C, Zener	R539,R540	442522714	270 Ω , 1/2W, Metal oxide film
D931,D932	223880 or 223896	GP101N4003 or 1N4003	R541~R544	442520224	2.2 Ω , 1/2W, Metal oxide film
D933	224150512 or 224650512 or	05AZ5.1Y or HZ5.1EB2 or	R545,R546	441720104	1 Ω , 2W, Metal oxide film
			R547~R550	4000080 or 4500022	0.47 Ω , 5W or 0.47 Ω , 5W, Metal plate
			R559,R560	442520824	8.2 Ω , 1/2W, Metal oxide film
			R564,R565	442520224	2.2 Ω , 1/2W, Metal oxide film
			R658	441626814	680 Ω , 1W, Metal oxide film
			R912	441623614	360 Ω , 1W, Metal oxide film
			R915	441625614	560 Ω , 1W, Metal oxide film
			R916	441623314	330 Ω , 1W, Metal oxide film
			R917	441625114	510 Ω , 1W, Metal oxide film
			R918,R919	441728204	82 Ω , 2W, Metal oxide film
			R920	442524724	4.7 k Ω , 1/2W, Metal oxide film
			R931	441621024	1 k Ω , 1W, Metal oxide film
			R932	442521024	1 k Ω , 1/2W, Metal oxide film
			R992	442521324	1.3 k Ω , 1/2W, Metal oxide film [D]
			R992	441626814	680 Ω , 1W, Metal oxide film [G][W][A][B]
				Relay	
			RL501	25065134	NRL-2P5A-DC24V-07

CIRCUIT NO.	PART NO.	DESCRIPTION
-------------	----------	-------------

	Jumper sockets	
JL302a,JL901a	25050267	NSCT-3P95
JL903a		
JL902a	25050272	NSCT-8P100
	Heatsink	
	27160229	
	Bracket	
	27141059	Ground

SPEAKER SWITCH PC BOARD (NASW-3548-3) PARTS LIST

CIRCUIT NO.	PART NO.	DESCRIPTION
	Coils	
L571,L572	231001	S-1.3B
	Resistors	
R571,R572	442520564	5.6 Ω, 1/2W, Metal oxide film
R573,R574	441623914	390 Ω, 1W, Metal oxide film
	Switch	
S571	25030290	NRSF-144-25SS
	Stereo jack	
P572	25045164	HLJ-4317-01-3020

SPEAKER TERMINAL PC BOARD (NAETC-3549-3, NAETC-3549-3A) PARTS LIST

CIRCUIT NO.	PART NO.	DESCRIPTION
	Terminal	
P571	25060134	NTM-8PDMN-063

SYSTEM CONTROL CIRCUIT PC BOARD (NADG-3550-2, NADG-3550-2A,NADG-3550-2B) PARTS LIST

CIRCUIT NO.	PART NO.	DESCRIPTION
	ICs	
Q301,Q321	22240050 or 22240191	μPC4570C or NJM4565DD
Q701	22240254	LC6520H-4030
Q751	22240243	LC6527C-3987
	Transistors	
Q702	2211455 or 2212495	2SA1015-GR or JA101-Q
Q703,Q704	2211255 or	2SC1815-GR or
Q752,Q753	2212485	JC501-Q
Q705	2211255 or 2212485	2SC1815-GR or JC501-Q
	Diodes	
D701	223163	1SS133
D702	221450562 or 224650562 or 224450562	0.5AZ5.6Y or HZ5.6EB2 or MTZ5.6B, Zener
D703,D751	225141	SEL2213C, LED
D711	225137CG or 225137DG or 225137DY	SEL2413ECG or SEL2413EDG or SEL2413EDY, LED
D712,D752	223163	1SS133
D714~D716		
D753		

CIRCUIT NO.	PART NO.	DESCRIPTION
-------------	----------	-------------

X701,X751	Osc. elements 3010150	CST4.00MGW
	Capacitors	
C301,C302	354780229	2.2 μF, 50V, Elect.
C305,C306		
C323,C324		
C307,C308	354780339	3.3 μF, 50V, Elect.
C321,C322	371128224	8200 pF, 50V, Mylar
C325,C326	354780109	1.0 μF, 50V, Elect.
C703,C753		
C327,C328	371123934	0.039 μF, 50V, Mylar
C331,C332	371122234	0.022 μF, 50V, Mylar
C701	3000051	0.047 F, 5.5V, SUPER
C705,C751	354741009	10 μF, 16V, Elect.
	Resistors	
R315	5104228	N11RHC250KWT22Z, Variable
R321,(R322)	5104229	N14RHC100KWT22Z, Variable
R335,(R336)		
R701	49163473404	47 KΩ×4, Network
	Switches	
S321	25035588	NPS-142-L550
S708	25035548	NPS-111-S510
	Holder	
	27190701A	(LED,OP)

KEY SWITCH PC BOARD (NASW-3551-2) PARTS LIST

CIRCUIT NO.	PART NO.	DESCRIPTION
	Diodes	
D704~D710	225137CG or 225137DG or 225137DY	SEL2413ECG or SEL2413EDG or SEL2413EDY, LED
	Switches	
S701~S707	25035548	NPS-111-S510
	Holders	
	27190702A	(LED, SEL)
	27190697	(LED, ST)

EQUALIZER CIRCUIT PC BOARD (NAETC-3552-2, NAETC-3552-2A) PARTS LIST

CIRCUIT NO.	PART NO.	DESCRIPTION
	ICs	
Q101,Q102	222570 or 22240191	NJM4560DX or NJM4565DD
	Capacitors	
C101,C102	372121014	100 pF, 50V, Styrene [G][W][A][B]
C103,C104	372121814	180 pF, 50V, Styrene [D]
C103,C104	372123314	330 pF, 50V, Styrene [G][W][A][B]
C107,C108	354741009	10 μF, 16V, Elect.
C111,C112	354722219	220 μF, 6.3V, Elect.
C113,C114	371126234	0.062 μF, 50V, Mylar
C115,C116	371121834	0.018 μF, 50V, Mylar
C119,C120	354721019	100 μF, 6.3V, Elect.
C131,C132	354742219	220 μF, 16V, Elect.

CIRCUIT NO.	PART NO.	DESCRIPTION
	Coils	
L101,L102	231030	NCH-1070 [G][W][A][B]
	Switch	
S101	25035608	NPS 142-L570
	Terminal	
P101	25045211	NPJ-2PDBL91
	Miniature jack	
P103	25045172	HSJ-1003-01-020

SELECTOR SWITCH CIRCUIT PC BOARD (NAAF-3553-2, NAAF-3553-2A) PARTS LIST

CIRCUIT NO.	PART NO.	DESCRIPTION
	ICs	
Q201	22240079	LC7821
Q202	22240025	LC4966
	Transistors	
Q203,Q204	2212285 or 2212286	2SC2878-A or 2SC2878-B
Q801,Q811	2211455 or 2212495	2SA1015-GR or JA101-Q
Q802,Q812	2211255 or 2212485	2SC1815-GR or JC501-Q
	Diodes	
D801	224150621 or 224650621 or 224450621	05AZ6.2X or HZ6.2EB1 or MTZ6.2A, Zener
	Capacitors	
C804	354780229	2.2 μ F, 50V, Elect.
C805,C811	354780109	1 μ F, 50V, Elect.
C806,C807	354744709	47 μ F, 16V, Elect.
	Terminals	
P201	25045213	NPJ-6PDBL-92
P202,P203	25045171	NPJ-4PDBL-65

POWER SWITCH CIRCUIT PC BOARD (NAPS-3554-2, NAPS-3554-2A,NAPS-3554-2B,NAPS-3554-2C) PARTS LIST

CIRCUIT NO.	PART NO.	DESCRIPTION
	Diode	
D905	223163	1SS133 [D][G][W]
	Capacitors	
C901	3500065A	0.01 μ F, AC400V/125V, IS [D][G][W]
C902	3500065A	0.01 μ F, AC400V/125V, IS
	Switch	
S901	25035550	NPS-111-L512P
	Terminal	
	25060092	NTM-1S33
	Relay	
RL901	25065357	NRL-1P5A-DC24V-051 [D]
RL901	25065341	NRL-1P15A-DC24V-047 [G][W]

CIRCUIT NO.	PART NO.	DESCRIPTION
	Fuse holder & Label	
F901a	250113	SN5051, Fuse holder [D][W]
F901b	29360462	5A/125V, Fuse label [D][W]
F902a	25050065	YSH4037, Fuse holder [G][W][A][B]
F902b	29360405	T2.5A/250V, Fuse label [G][W][A][B]
F903a	25050065 29360626-1	YSH4037, Fuse holder [G] Label, Caution

VOLUME CONTROL CIRCUIT PC BOARD (NAETC-3556-2) PARTS LIST

CIRCUIT NO.	PART NO.	DESCRIPTION
	IC	
Q351	222963	LB1630
	Capacitor	
C353	354741009	10 μ F, 16V, Elect.
	Resistors	
R351,(R352)	5104234	N16RGM50KA30F, Variable
	Bracket	
	27141059	Ground

NOTE

- [D]: Only 120V models
- [G]: Only 220V models
- [W]: Only 120V/220V models
- [A]: Only Australian models
- [B]: Only British models

IC BLOCK DIAGRAM

LC6520H-4030 (Micro computer)

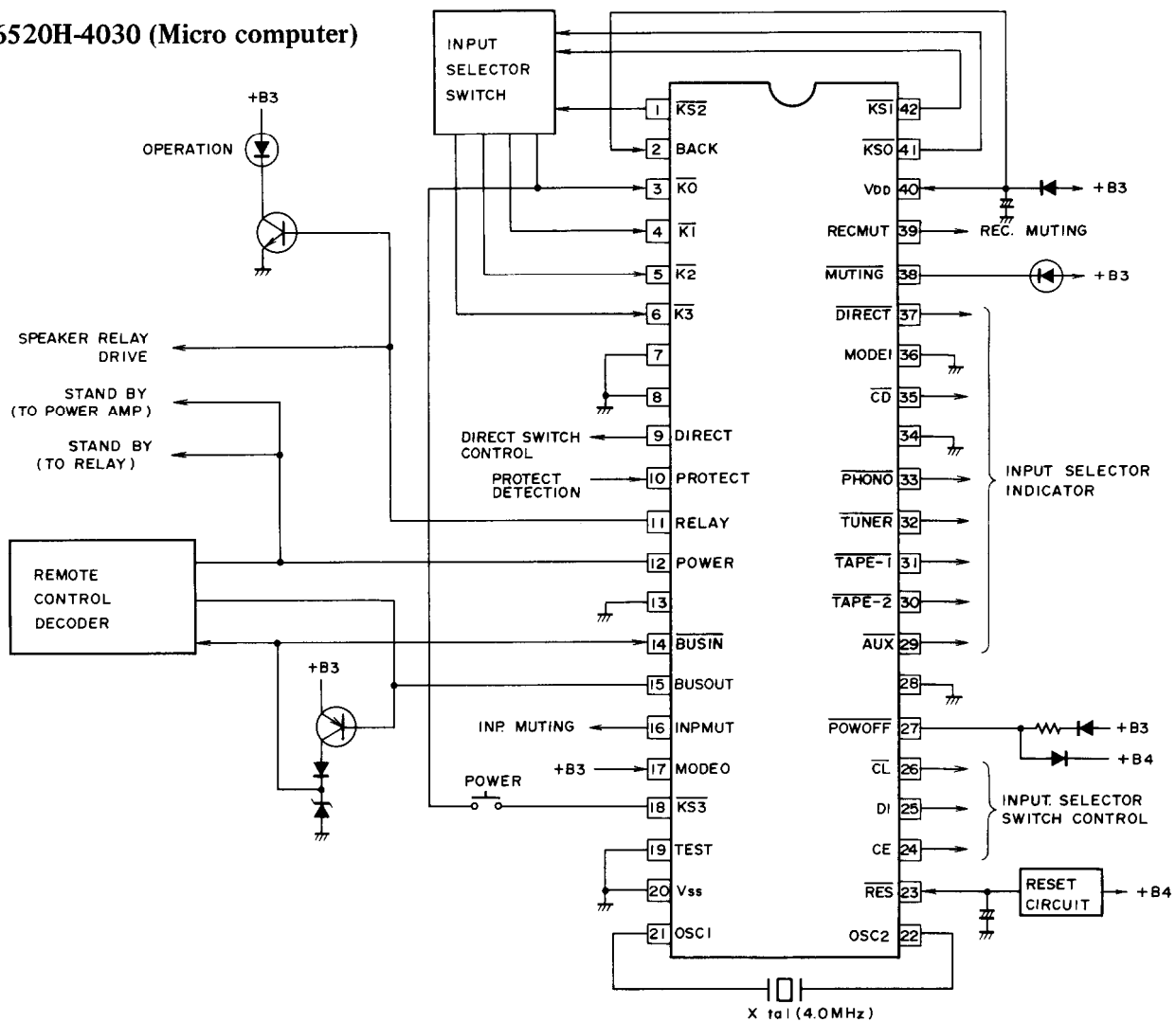

Pin No.	Pin name	Symbol	Function
1	PA2	KS2	Key scan output terminal.
2	PA3	BACK	Input terminal for initial settings. Fixed at "H".
3	PB0	K0	Key input terminals.
4	PB1	K1	
5	PB2	K2	
6	PB3	K3	
7	PC0	—	Fixed at "L".
8	PC1	—	Fixed at "L".
9	PC2	DIRECT	DIRECT switch on is "H".
10	PC3	PROTECT	Protect input terminal.
11	PD0	RELAY	Speaker relay control terminal. Switches to "H" 5 second after power is turned on. Immediately switches to "L" when POW OFF terminal switches from "H" to "L".
12	PD1	POWER	Standby control.
13	PD2	—	Ground
14	PD3	BUS-IN	System code input terminal. Active: "H"
15	PE0	BUSOUT	System code output terminal. Active: "L"
16	PE1	INPUMT	Input selector muting output terminal.
17	PE2	MODEO	Fixed at "H". Initial setting when power is turned on.
18	PE3	KS3	
19	TEST	TEST	Ground
20	V _{SS}	V _{SS}	Ground
21	OSC1	OSC1	Ceramic oscillator connector terminals (4 MHz).
22	OSC2	OSC2	

23	RES	RES	RESET input terminal.
24	PF0	CE	Chip-enable output terminal. Connected to analog switch CE terminal.
25	PF1	DI	Serial data output terminal. Connected to analog switch DI terminal.
26	PF2	CL	Serial data output terminal. Connected to analog switch CL terminal.
27	PF3	POW $\overline{\text{OFF}}$	Power off sensor input terminal.
28	PG0	—	Ground
29	PG1	AUX	INPUT SELECTOR display output terminals. Input selector setting position is "L".
30	PG2	TAPE-2	
31	PG3	TAPE-1	
32	PI0	TUNER	
33	PI1	PHONO	
35	PI3	CD	
34	PI2	—	Ground
36	PJ0	MODE1	Power-on initial setting input terminal. Fixed at "L".
37	PJ1	DIRECT	Direct display output terminal.
38	PJ2	—	Muting display output terminal.
39	PJ3	RECMUT	Muting control output terminal for REC. output.
40	V _{DD}	V _{DD}	Power supply terminal (+5V).
41	PA0	KS0	Key scan output terminals.
42	PA1	KS1	

LC7821 (Analog switch)

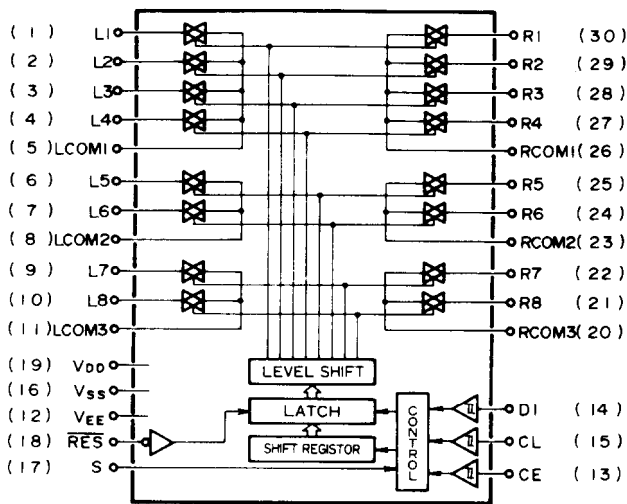

LB1630 (Motor drive)

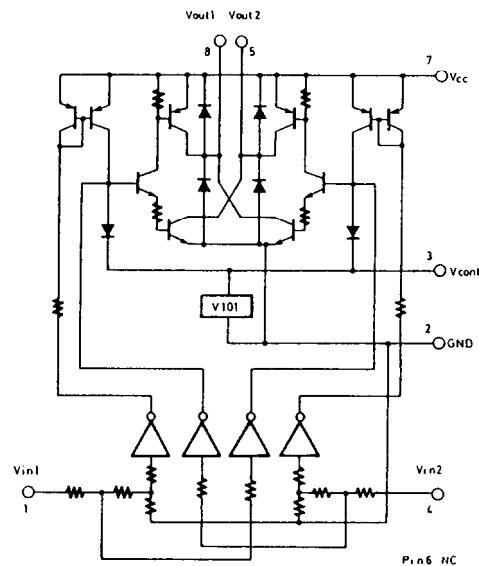

LC4966 (Switch)

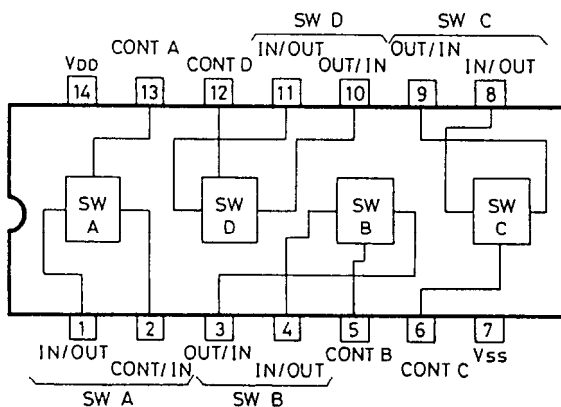

TRUTH TABLE

IN 1	IN 2	OUT 1	OUT 2	MOTOR
H	L	H	L	Normal
L	H	L	H	Reverse
H	H	OFF	OFF	Wait
L	L	OFF	OFF	Wait

LC6527C (Remoto controlle decoder)

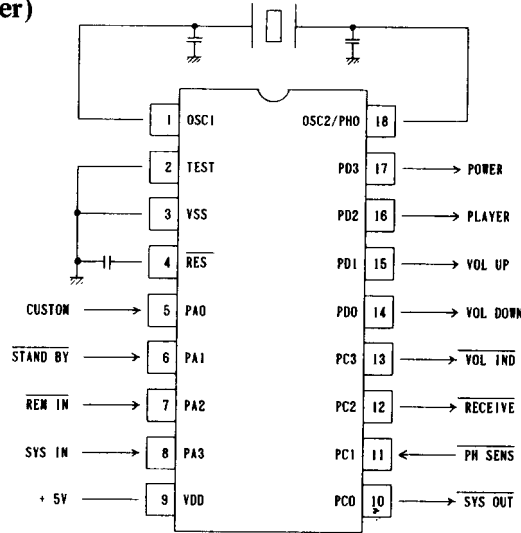

Pin No.	Pin name	Symbol	Function									
1	OSC1	OSC1	Ceramic oscillator connector terminal. 4 MHz. 1/3 division.									
2	TEST	TEST	Test terminal. Connected to V _{SS} .									
3	V _{SS}	V _{SS}	Ground terminal									
4	RES	RES	Reset terminal.									
5	PA0	CUSTOM	Decoded input terminal with switchable custom codes and operations. <table border="1" style="margin-left: 20px;"> <thead> <tr> <th>Custom input</th> <th>Custom code</th> <th>Operation</th> </tr> </thead> <tbody> <tr> <td>L</td> <td>D26D</td> <td>System (export)</td> </tr> <tr> <td>H</td> <td>D225</td> <td>Tuner</td> </tr> </tbody> </table> This terminal is read when power is turned on and the above initial settings are carried out.	Custom input	Custom code	Operation	L	D26D	System (export)	H	D225	Tuner
Custom input	Custom code	Operation										
L	D26D	System (export)										
H	D225	Tuner										
6	PA1	STAND BY	Standby condition sensor terminal. Only the POWER code is decoded when STAND BY input is "L".									
7	PA2	REMIN	Remote control signal input terminal. Active: "L". The photo-sensor output is connected to this terminal.									
8	PA3	SYS IN	System code input terminal. Active: "H". Output system codes are monitored at this terminal.									
9	V _{DD}	V _{DD}	Power supply (+5V) terminal.									
10	PC0	SYS OUT	System code output terminal. Active: "L". This terminal output the appropriate system code in response to input from the remote control.									
11	PC1	PH SENS	PHONO sensor input terminal. Active: "L". This terminal is valid during system. The remote control K64 code is decoded only when this terminal is "L".									
12	PC2	RECEIVE	RECEIVE display output terminal. Active: "L". "L" when remote control codes for decoding are being input.									
13	PC3	VOL IND	VOLUME indicator output terminal. Active: "L". Normally "L". Outputs waveform which is "H" for 250 ms then "L" for 250 ms during VOLUME UP or VOLUME DOWN output.									
14	PD0	VOL DOWN	VOLUME DOWN control output terminal. Active: "H". Output is "H" when remote control K4 code is input.									
15	PD1	VOL UP	VOLUME UP control output terminal. Active: "H". Output is "H" when remote control K3 code is input.									
16	PD2	PLAYER	PLAYER control output terminal. Active: "H". This terminal is valid during system. Output is "H" for 200 ms if remote control K64 code is input when PH SENS input is "L".									
17	PD3	POWER	POWER control output terminal. Active: "H". Reverses output whenever remote control K5 code is input.									
18	OSC2/PHO	OSC2	Ceramic oscillator connector terminal. 4 MHz 1/3 division.									

PARTS LIST OF PACKING

REF. NO.	PART NO.	DESCRIPTION	
A851	29051921	MASTER CARTON BOX	
A852	29091322B	PAD, LEFT	[D]: ONLY 120V MODELS
A853	29091323B	PAD, RIGHT	[G]: ONLY 220V MODELS
A854	261504	W=30 mm, PAPER TAPE	[W]: ONLY 120V/220V MODELS
A865	29100063	750 × 580mm, POLY-VINYL BAG	[N]: ONLY U.S.A MODELS
A866	282301	SEALING HOOK	[A]: ONLY AUSTRALIAN MODELS
A867	260012	W=50 mm, DAMPLON TAPE	[B]: ONLY BRITISH MODELS
	29360778	LABEL (FLASH)	[N]
A868	29380054	BS-2, AC COARD TAG	[B]
	29360863	LABEL (CAUTION)	[B]

ACCESSORY BAG ASS'Y

29341416	INSTRUCTION MANUAL	[D]
29341394	INSTRUCTION MANUAL	[G][W][A][B]
29365019	WARRANTY CARD	[N]
29365022	WARRANTY CARD	[B]
29358002G	SERVICE STATION LIST	[N]
29100097	250 x 350, POLY-VINYL BAG	
24140142A	RC-142S, REMOTE CONTROL UNIT	[D]
24140143	RC-143S, REMOTE CONTROL UNIT	[G][W][A][B]
3010054	UM-3, FOUR BATTERIES	
2010169	3.5 MINI PLUG	
25055040	CV-K-2, CONVERSION PLUG	[W]

SYSTEM CONNECTIONS

General

Switch the main power switch off before performing connections.
Also be sure to perform left and right channel connections properly.

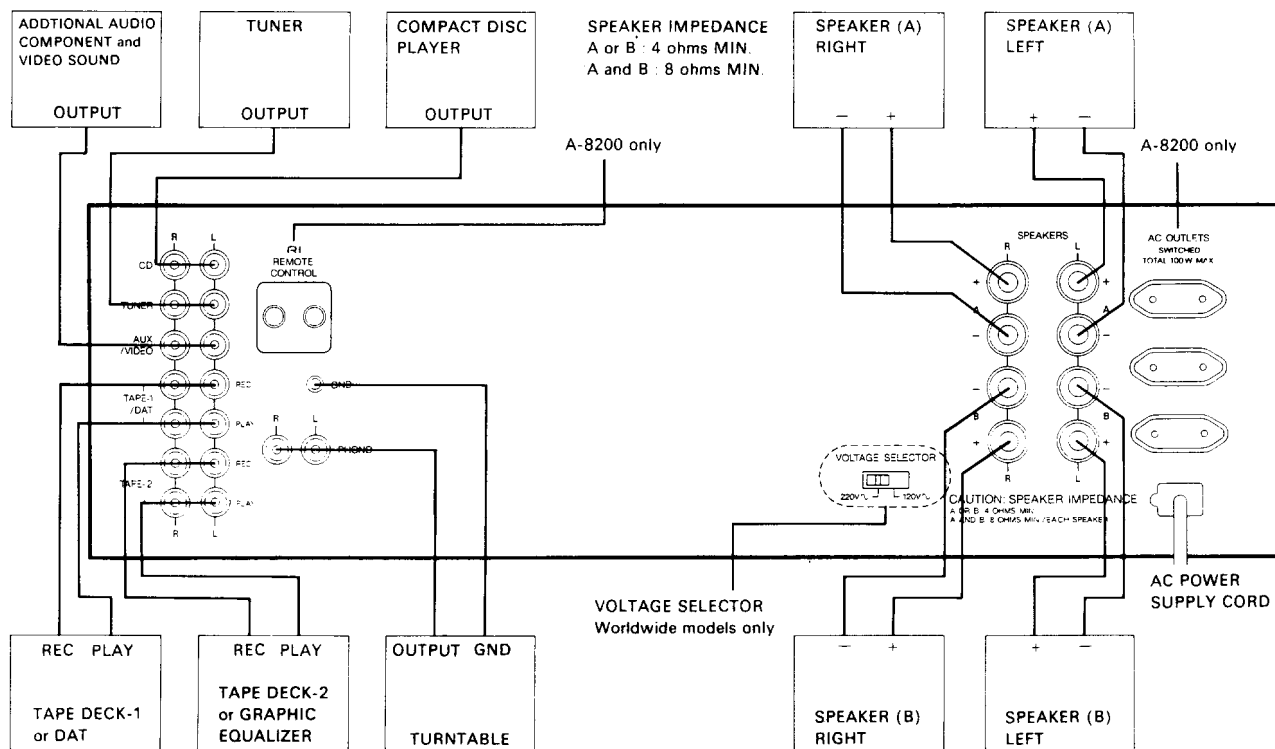

FRONT PANEL FACILITIES

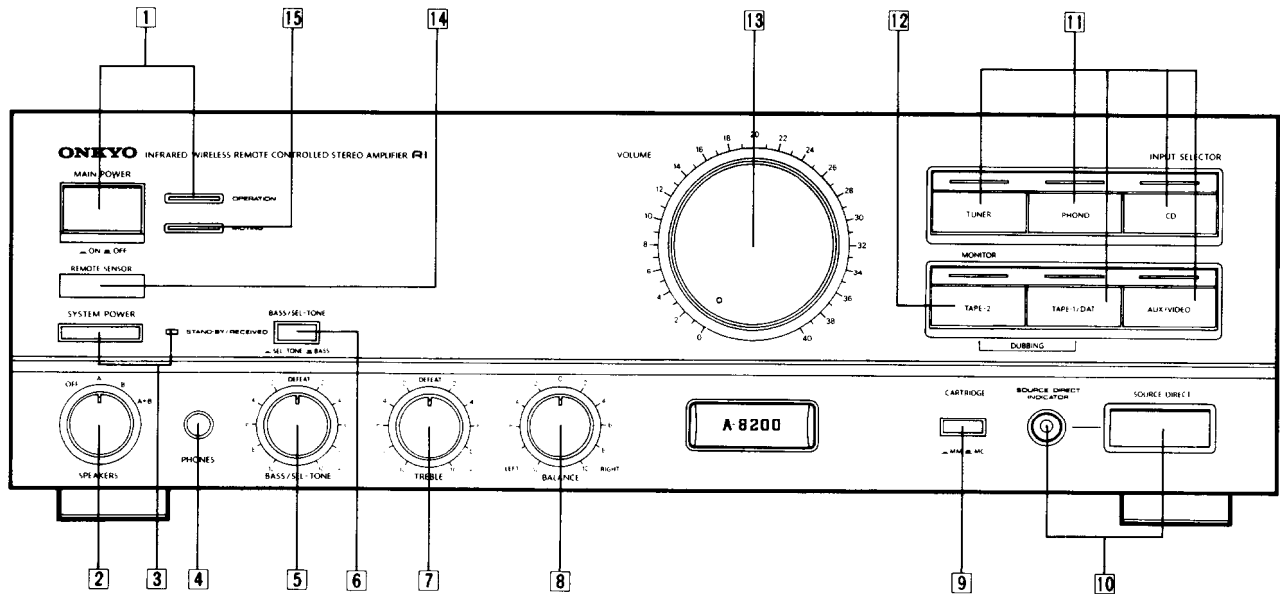

Remote control transmitter RC-143S/142S

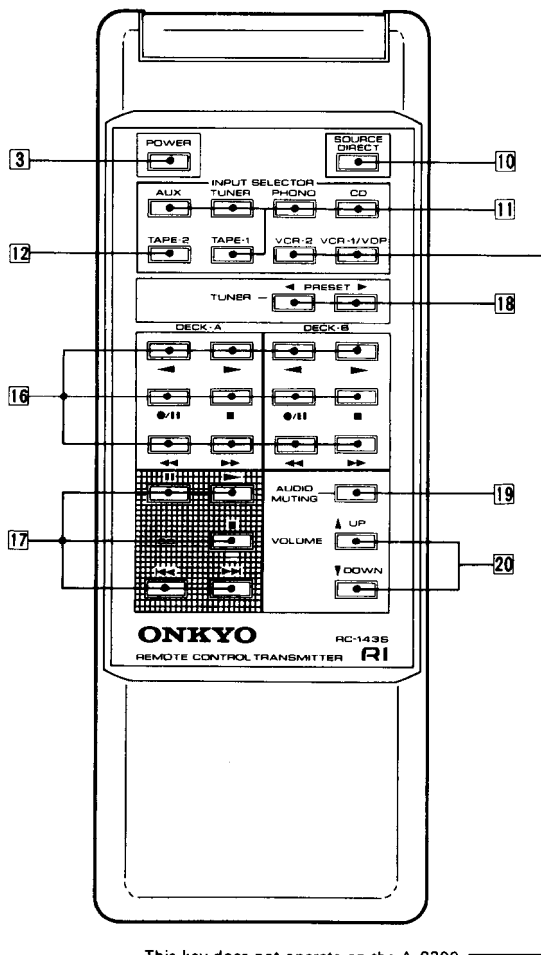

1. Main power switch and operation indicator (MAIN POWER)
2. Speaker selector (SPEAKERS)
OFF, A, B, A+B
3. System power button and standby/received indicator (SYSTEM POWER and STANDBY/RECEIVED)
4. Headphone jack (PHONES)
5. Bass control/Selective tone control (BASS/SEL-TONE)
6. Bass/Selective tone switch (BASS/SEL-TONE)
7. Treble control (TREBLE)
8. Balance control (BALANCE)
9. Cartridge selector (CARTRIDGE)
10. Source direct and indicator (SOURCE DIRECT)
11. Input selector and indicators (INPUT SELECTOR)
TUNER, PHONO, CD, TAPE-1/DAT, AUX/VIDEO
12. Tape monitor and indicator (TAPE-2/MONITOR)
13. Volume control (VOLUME)
14. Remote control sensor
15. Muting indicator

Remote control transmitter controls (RC-142S)

16. Tape operation keys (DECK-A, DECK-B)
REVERSE PLAY, FORWARD PLAY, REC PAUSE, STOP, FAST REWIND, FAST FORWARD
17. CD Operation keys (CD)
PAUSE, PLAY, STOP, DOWN, UP
18. Tuner operation keys (PRESET)
19. Audio muting key (AUDIO MUTING)
20. Volume keys (UP, DOWN)
21. Phono operation key (PLAY/REJECT)

Remote control transmitter controls (RC-143S)

16. Tape operation keys (DECK-A, DECK-B)
REVERSE PLAY, FORWARD PLAY, REC PAUSE, STOP, FAST REWIND, FAST FORWARD
17. CD Operation keys (CD)
PAUSE, PLAY, STOP, DOWN, UP
18. Tuner operation keys (PRESET)
19. Audio muting key (AUDIO MUTING)
20. Volume keys (UP, DOWN)

BLOCK DIAGRAM

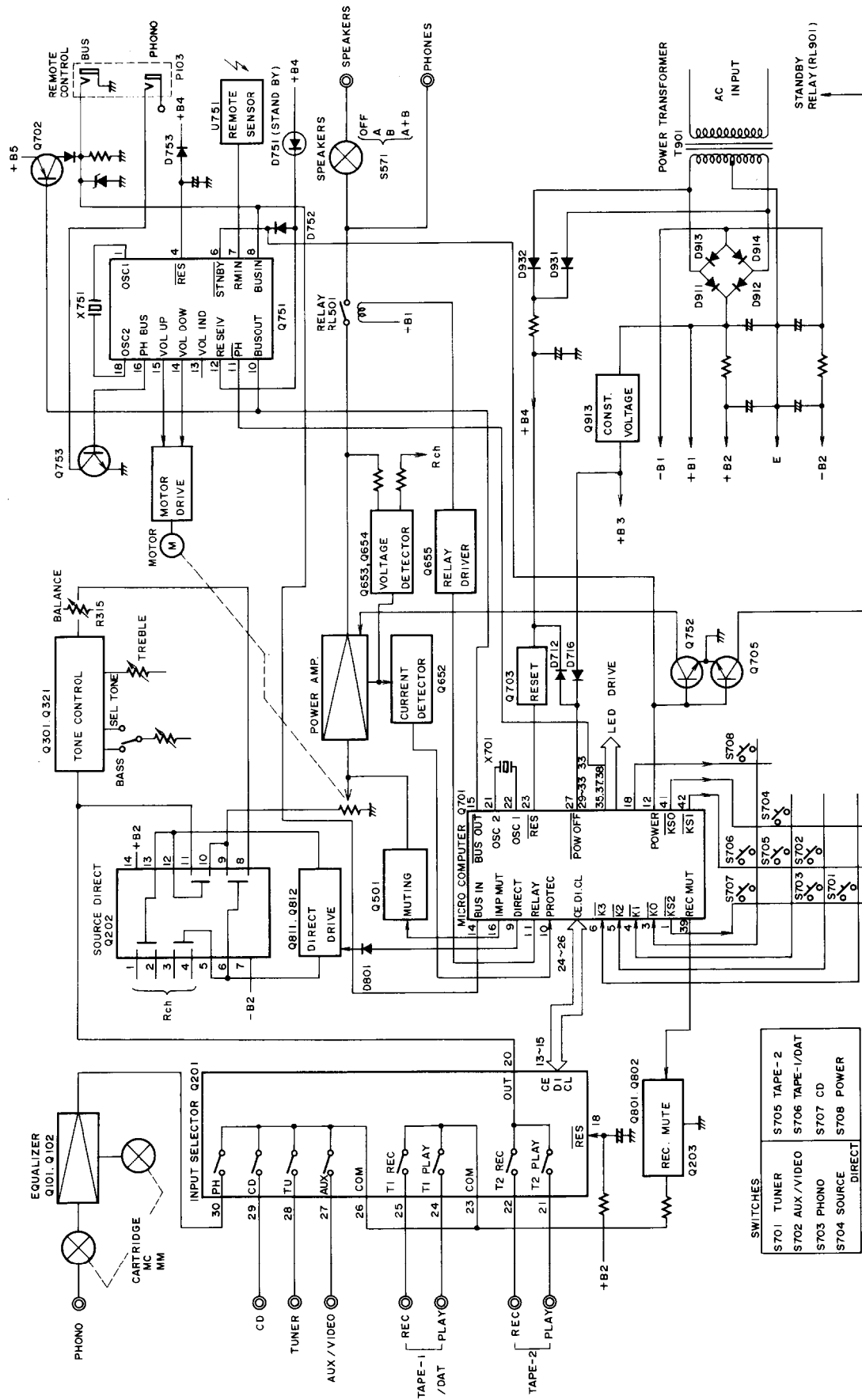

SWITCHES

S701	TUNER	S705	TAPE-2
S702	AUX./VIDEO	S706	TAPE-1/DAT
S703	PHONO	S707	CD
S704	SOURCE	S708	POWER
	DIRECT		